

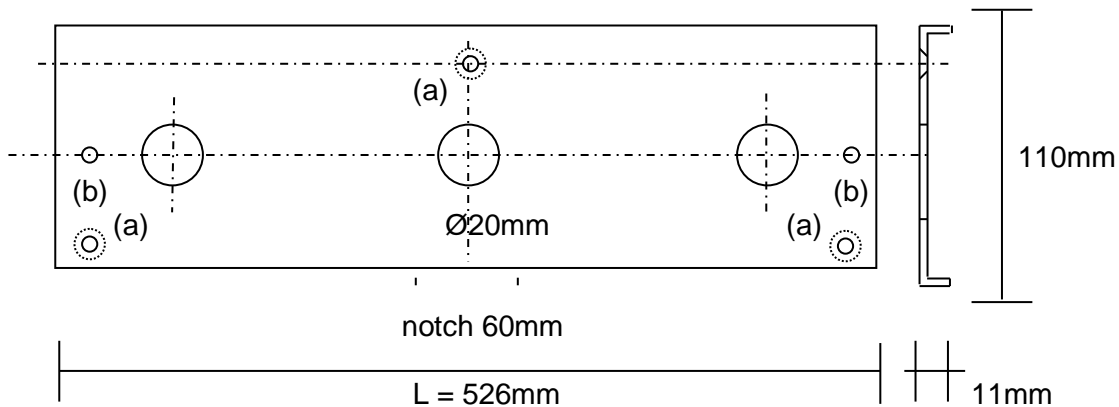

V2A pre-mounting base for LED illuminated display LWA-130-PL2



- 2 drill holes \varnothing 20mm
- 3 countersunk holes \varnothing 8/12mm (a)
- 2 threaded holes \varnothing M5 (b)
- 1 notch 60x11mm

Material: V2A brushed 2.0mm and deburred

Installation of the LWA to the wall:

1. Attach the pre-mounting base to the wall using 3 countersunk screws
2. Insertion of cable from the rear through the 20mm drill hole
3. LWA:
 - Unscrew one end cap
 - Pull out the PCB and front plate and store temporarily
 - Feed cable through the 20mm drill hole
 - Screw the LWA housing to the threaded holes of the plinth panel using two M5x10 screws
4. Position the cable to the left
5. slide the PCBs (Master and Slave) in the 4rd slot from the bottom and clamp the cable at the terminals
6. slide the front plate into the top slot of the housing
7. Function test
8. Screw on the end cap to the housing
9. Clean the front plate and the housing with a soft cloth